

5000TOCi Sensor Standard Operating Procedure

for System Suitability Testing to meet
USP <643> and EP 2.2.44

METTLER TOLEDO

A graphic element consisting of a series of parallel, slightly curved lines that form a diamond or arrow-like shape pointing downwards and to the right. The lines are more densely packed in the center and become sparser towards the edges.

©Mettler-Toledo Thornton, Inc. 2011

No part of this manual may be reproduced or transmitted in any form or by any means, electronic or mechanical, including photocopying (other than where specifically noted), for any purpose without the express written permission of Mettler-Toledo, Inc.

U.S. Government Restricted Rights: This documentation is furnished with Restricted Rights.

**METTLER TOLEDO THORNTON RESERVES THE RIGHT TO MAKE REFINEMENTS OR
CHANGES WITHOUT NOTICE.**

This document contains proprietary information, which is protected by copyright. All rights are reserved. No part of this document may be photocopied (other than where specifically noted), reproduced or translated, into another language without the prior written consent of Mettler-Toledo Thornton, Inc.

IMPORTANT SAFETY INFORMATION

Please read thoroughly before operating the CAL/SST Module-

- Follow all warnings, cautions, and instructions indicated on and supplied with this product.
- Install equipment as specified in this instruction manual. Follow appropriate local and national codes.
- Use only factory documented components for repair. Tampering or unauthorized substitution of parts and procedures can affect the performance and cause unsafe operation of your process as well as void factory warranties.
- Protective covers must be in place unless qualified personnel are performing maintenance.
- If this equipment is used in a manner not specified by the manufacturer, the protection provided by it against hazards may be impaired.
- Prior to shipping the sensor back to the factory for repair or re-calibration, water **MUST** be drained from sensor to avoid damage due to freezing.

WARNINGS:

- Installation of cable connections and servicing of this product require access to shock hazard voltage levels.
- Main power must employ a switch or circuit breaker as the disconnecting device for the equipment.
- Electrical installation must be in accordance with the National Electrical Code and/or any other applicable national or local codes.
- Safety and performance require that this instrument be connected and properly grounded through a three-wire power source.

This manual includes safety information with the following designations and formats:

WARNING: POTENTIAL FOR PERSONAL INJURY.

CAUTION: possible instrument damage or malfunction.

NOTE: important operating information.



Warning: UV RADIATION HAZARD

Apply power to UV lamp only when installed in housing in accordance with instruction manual.

DO NOT remove UV lamp from housing unless power is off.

Always protect eyes and skin from exposure to UV light

Definition of Equipment Symbols



On the instrument indicates: Warning risk of electric shock.



On the instrument indicates: Caution (refer to accompanying documents).



On the instrument indicates: There is alternating current present.

This page is intentionally blank.

TABLE OF CONTENTS

1.	INTRODUCTION.....	1
2.	SCOPE.....	2
3.	BACKGROUND.....	2
4.	PRINCIPLE OF ANALYSIS.....	2
5.	APPARATUS REQUIRED.....	2
6.	TEST PROCEDURE.....	3
6.1.	System Preparation.....	3
6.2.	System Suitability Test Report Preparation.....	3
6.3.	Install CAL/SST Module.....	4
6.4.	System Suitability Test Procedure.....	5
6.5.	Rinse Sensor and System Suitability Test Kit.....	9
7.	COMPLETE SYSTEM SUITABILITY TEST REPORT.....	10
	The M800 Transmitter will automatically calculate the necessary values, determine the Pass/Fail results of the System Suitability Test, and store these values in the 5000TOCi Sensor. However, if manual calculation of the results is desired, follow these steps to complete Section 4 of the System Suitability Test Report.....	10
7.1.	Limit Response and System Suitability Response.....	10
7.2.	Response Efficiency.....	10
7.3.	System Suitability Test Acceptance.....	10
	SYSTEM SUITABILITY TEST REPORT.....	11

This page is intentionally blank.

1. Introduction

This procedure describes the method for performing a System Suitability Test using a Thornton 5000TOCi Sensor for total organic carbon (TOC) measurement.

For all the Pharmaceutical Waters listed below, one of the acceptance criteria for the water is to “meet the TOC requirement”. Several pharmacopoeia have established TOC specifications (for example USP General Chapter <643>, EP Chapter 2.2.44, and JP XV Chapter 21). These chapters provide 1) guidance on the methodology for TOC testing, 2) criteria for establishing instrument acceptance, and 3) TOC limits for the sample to be tested.

Some types of water subject to TOC testing are (but not limited to):

- USP Purified Water
- USP Water for Injection
- EP Purified Water – TOC measurement may be performed in lieu of oxidizable substances test
- EP Highly Purified Water
- EP Water for Injections
- JP Purified Water
- JP Water for Injection
- ChP Water for Injection
- ChP Purified Water – TOC measurement may be performed in lieu of oxidizable substances test

The principal criteria to establish the acceptance of the instrument are 1) limit of detection less than 0.05 mg carbon/L, 2) calibration capability of the instrument, 3) capability to not include inorganic carbon (CO₂) in the TOC measurement, and 4) meeting System Suitability Testing periodically. This document focuses on the Standard Operating Procedure for performing the System Suitability Test on a Thornton 5000TOCi Sensor.

The purpose and the value of the System Suitability Test are based on the premise that TOC measurements are not direct measurements of organic carbon, but they are indirect measurements of other carbon-based chemicals. Most TOC measurement systems share the technology of converting the organic carbon to CO₂, and the CO₂ is measured by various means.

The System Suitability Test intention is to challenge the instrument by verifying that it responds equally to two types of chemicals that challenge its measurement capability. In this case, the two chemicals specified in the pharmacopoeial chapters are sucrose and 1,4-benzoquinone. They are commonly referred to as easy-to-oxidize and hard-to-oxidize chemicals, respectively.

In the case of many of today’s TOC measurement systems, there are two key mechanisms for the conversion of organic carbon to CO₂:

- The ability to break carbon-carbon, carbon-hydrogen, and carbon-oxygen bonds. These are the most prevalent chemical bonds found in organic impurities. The strength of each bond depends on the molecule and bond type. Regardless, these bonds need to be broken to form CO₂.
- The ability to oxidize molecular organic carbon (in oxidation states ranging from -4 to +2) to its oxidized form, CO₂, where the oxidation state of carbon is +4. Therefore, electrons are required to be removed from each carbon, and electron acceptors such as the hydroxyl radical (OH·) are formed in water in the presence of deep UV light.

Since organic carbon appears in various forms in nature and subsequently in water systems, a wide variety of oxidation states and chemical forms are found in water systems. The challenge to the TOC measurement system is to oxidize two chemicals equally. Because of their quite different chemical structure, sucrose and 1,4-benzoquinone will challenge the bond-breaking and oxidation capability of the TOC measurement technology. Note that the same concept of the challenge would still apply if another technology were to be applied (such as conversion to CH₄).

The standard solution is a theoretically easy-to-oxidize solution that gives an instrument response at the attribute limit – in this case 500 µg Carbon/L. The technology is qualified by challenging the capability of the instrument using a theoretically difficult-to-oxidize solution in the system suitability portion of the method.

2. Scope

This document provides a procedure to qualify the Thornton 5000TOCi Total Organic Carbon Sensor for use with the M800 transmitter as a TOC measurement device for various compendial Pharmaceutical waters listed above. This may be applicable to other waters also. This method is to be performed on a sensor and transmitter that has been calibrated. The acceptance of this measurement system for quality attribute testing is dependent on its location(s) in the water system. The instrument location (or the sampling point) must reflect the quality of the water used in the production process.

This procedure describes one acceptable method to determine system suitability. Alternative procedures may be acceptable if they meet the fundamental requirements of USP <643>, EP 2.2.44, etc.

3. Background

On November 15, 1996, the requirements for testing specific attributes of USP Purified Water and WFI were modified to reflect changes in instrumentation and quality testing. The two profound changes were:

- The elimination of tests for chloride, ammonia, sulfate, carbon dioxide, and calcium and subsequent replacement by uncompensated conductivity and temperature measurements. This is described in USP <645>.
- The option to perform TOC measurements instead of the Oxidizable Substance Test for USP Purified Water and WFI. Eventually, the Oxidizable Substances Test was deleted for these bulk waters.

The major impetus for these changes was the opportunity to eliminate costly, labor-intensive tests that were qualitative at best, and replace them with quantitative tests that represented current industry norms. The on-line versatility of these measurements made these new tests more attractive. Later, other major pharmacopoeias have adopted similar requirements. You should consult the pharmacopoeia of interest for current requirements.

4. Principle of Analysis

Organic impurities are introduced into the water from the source water, purification processes, components in the distribution system, and from biofilm in the system. TOC is an indirect measure of organic molecules measured as carbon. TOC can also be used as a process control attribute to monitor the performance of unit operations comprising the purification and distribution system.

The Thornton 5000TOCi Sensor and M800 transmitter measures and reports the amount of organic carbon in high purity waters by oxidizing organic carbon to CO₂ with appropriate UV radiation. The resulting change in conductivity is used to calculate the amount of organic carbon present.

5. Apparatus Required

- Thornton 5000TOCi Sensor (PN's 58 036 031, 58 036 032, 58 036 033, and 58 036 034,) with its associated instruction manual and installation kit.
- Thornton M800 Transmitter (various part numbers) with associated instruction manual and patch cable.
- Thornton CAL/SST Kit (58 091 559 or 58 091 566).
- Thornton System Suitability Solutions Kit (58 091 526) which may also be obtained with combined calibration and SST solution kit P/N's 58 091 537 or 58 091 568.

6. Test Procedure

Note: Use the 'Hold Outputs' function in the M800 Transmitter to hold the relay and analog outputs so that alarms are not triggered during any service procedures. To avoid causing unintentional system responses, please ensure that all M800 analog and relay output 'Hold' configurations are properly set prior to performing a System Suitability Test.

Throughout the test procedure, the units "ppb" or "ppb Carbon" and "µg Carbon/L" will appear. They are identical for this procedure. "ppb" (or ppm) is the common terminology used throughout the industry, though it is not a recognized SI unit. "µg Carbon/L" (or mg Carbon/L) are the units referred to in the pharmacopoeia.

6.1. System Preparation

1. Prior to this test, install and operate the 5000TOCi Sensor and M800 transmitter according to their operations manuals.
2. Run process water through the sensor for at least 30 minutes.

6.2. System Suitability Test Report Preparation

The 5000TOCi will automatically record and store the results of the three most recent System Suitability Tests. These results can be viewed from the M800 by pressing the **ISM** icon and selecting SST Info. However, a sample System Suitability Test Report is provided at the end of this Operating Procedure to facilitate a written record of the System Suitability Test if desired. This sample can be copied and used freely, or an equivalent document may be generated locally, to meet specific requirements

1. Fill in Section 1 of the System Suitability Test Report:
 - a. Enter today's date, and the local 5000TOCi Sensor ID if one is assigned.
 - b. Enter the 5000TOCi Sensor information, which can be found by pressing the **ISM** icon from the M800 and selecting Sensor Info. Select the channel associated with the TOC sensor to be tested, and record the necessary information.

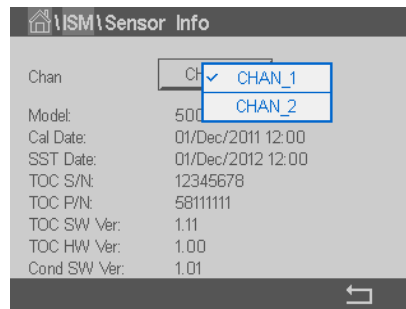

- c. Enter the M800 Transmitter information which can be found by pressing the **ISM** icon from the M800 and selecting HW/SW Version. Ensure that Transmitter is selected in the drop-down selector provided.



2. Fill in Section 2 of the System Suitability Test Report by entering the Test Solution information. This information can be read directly from the labels on the Test Solution bottles, or from the Mylar bags in which the bottles are shipped.

6.3. Install CAL/SST Module

CAL/SST Module kits 58 091 559 and 58 091 566 each provide the equipment needed to perform a system suitability test on the 5000TOCi Sensor (PN's 58 036 031, 58 036 032, 58 036 033, and 58 036 034). Components contained in this kit include the Calibration/SST module with conductivity sensor, a mounting bracket, connecting tubing equipped with quick-disconnect fittings, a universal power supply and assorted tools. These kits are designed for use with Thornton Standard Solution bottles included in the System Suitability Solutions Kits.

TOC Calibration and SST Kit Installation and Setup

1. Remove the mounting bracket from the carrying case and place on top of the 5000TOCi Sensor to be tested. See Figure 1.
2. Connect the CALI/SST Module to the mounting bracket. Ensure that the bracket and module are aligned to the left side of the sensor so that UV Lamp power button is accessible and the indicating LED's are visible, and the tab on the left side of the mounting bracket is positioned beneath the upper-left mounting foot of the sensor.
3. Remove the 60 micron filter assembly from the 5000TOCi inlet.
4. Attach the threaded end of the connection tube equipped with the male quick-disconnect fitting to the 5000TOCi Sample Inlet connection. After the threaded connection is made, push the quick-disconnect fitting into mating connector found on the top right side of the Cal/SST pump module. Ensure proper connection is made.
5. Set selector valve on CAL/SST pump module to "SST/TOC CAL" position. Figure 1 shows the proper installation of the CAL/SST pump module.
6. Verify the pump switch is in the off position. The switch is located on the right side of the module.
7. Connect the Universal Power Supply to the pump and to 100–240 VAC 50-60 Hz power. The kit includes a universal AC adaptor with assorted international standard connectors. Select the appropriate AC connector, and install it onto the AC adaptor and connect to the AC supply.

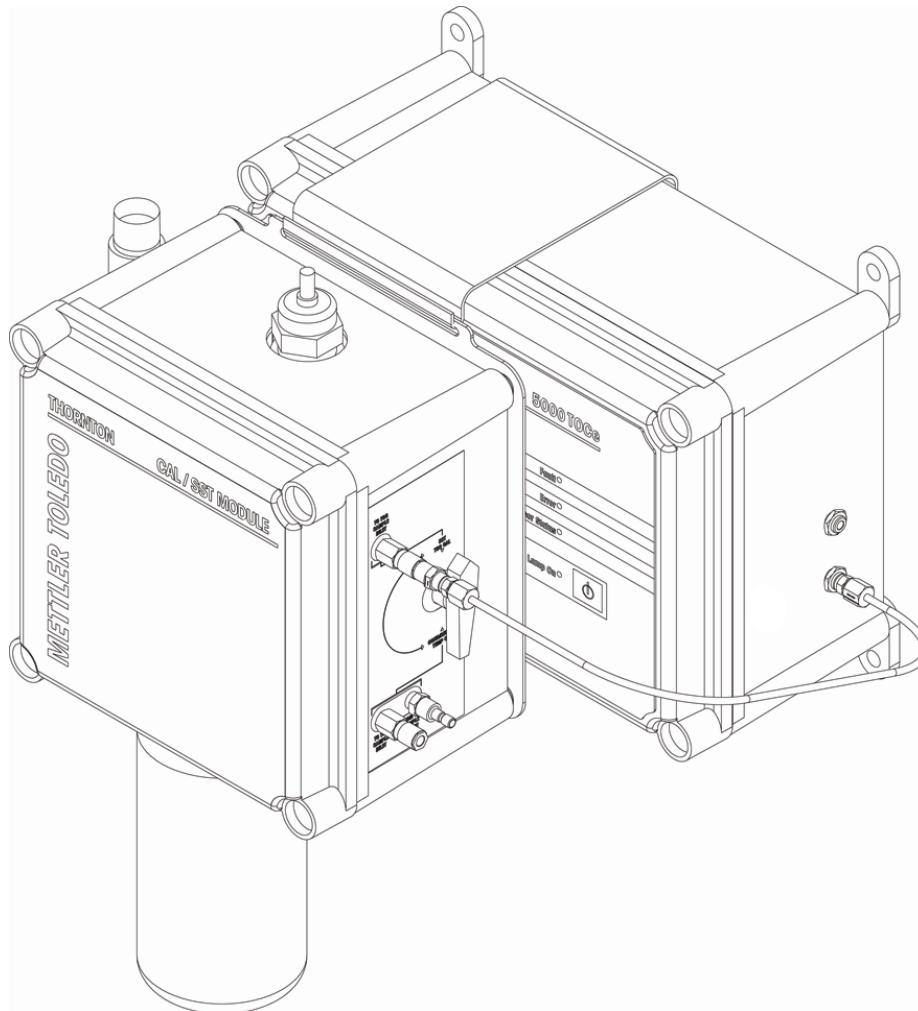

Figure 1. CAL/SST Pump Module Installation and Setup

Attaching System Suitability Standards bottles to the CAL/SST Pump Module

When required by the procedure, an SST Standard solution bottle can be attached to the CAL/SST Pump Module as follows:

1. Remove the threaded grey, protective cap from the bottom of the CAL/SST Pump Module.
2. Wearing clean protective gloves to avoid contamination, insert a silicone suction tube onto the suction fitting located in the bottle receptacle as shown in Figure 2. A fresh suction tube should be used for each SST test. Protective gloves and a replacement suction tube are provided with each SST solution kit.
3. Break the protective seal on the SST solution bottle and remove cap. Set cap aside for re-use if any SST solutions remain after completion of the test.
4. Insert free end of the suction tube into the mouth of the bottle while raising the bottle into place. Screw SST solution bottle directly into the solution bottle receptacle at the base of the CAL/SST pump module.

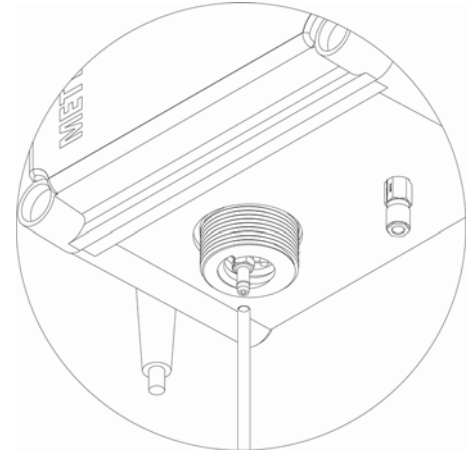

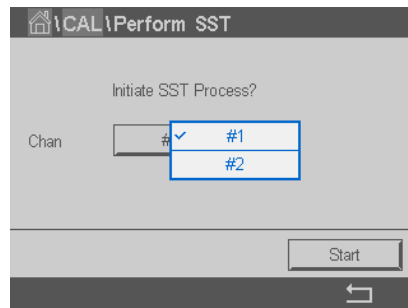

Figure 2. Suction Tube installation

The CAL/SST module is now ready to perform the SST test. Proceed to section 6.4 System Suitability Test Procedure.

6.4. System Suitability Test Procedure

1. From the M800, press the  icon and select 'Perform SST' option. Select the M800 channel associated with the TOC sensor to be tested from the provided drop-down selector, and press 'Start' to begin the SST process.



2. Enter the requested identifying information for the Reagent Water (R_w), sucrose Standard Solution (R_s) and Benzoquinone System Suitability Solution (R_{ss}) in the fields provided. The required information can be found on the labels attached to the solution bottles, and to the Mylar bags in which the bottles are shipped. After entering the information for each solution, press 'Next' to advance to the next screen

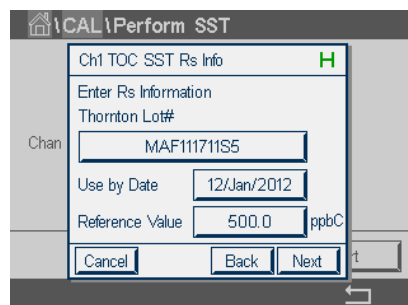

- Follow the on-screen prompts to connect and configure the test apparatus using the details instructions provided in Section 6.3 Install CAL/SST Module.
- When instructed, attach the R_W bottle to the Cal/SST module and activate the pump.
- After completing an automatic purge countdown, the system will monitor the TOC reading to determine stability and then automatically record the readings once stable.

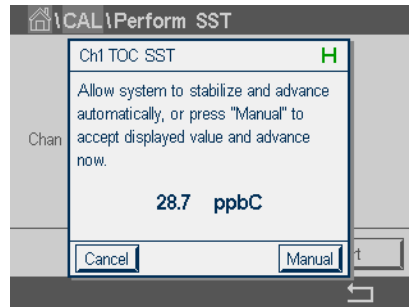

If a system fault prevents the readings from automatically stabilizing, 'Manual' can be pressed to complete the SST process. Using 'Manual' to complete the SST process should be used only for diagnostic purposes, and should not be used for determination of System Suitability.

- When instructed, turn off the Cal/SST module pump and press 'Next' to display the R_W test results. If desired, record the results in Section 3 of the System Suitability Worksheet at the end of this document, or on an equivalent document. Press 'Next' when ready to proceed.

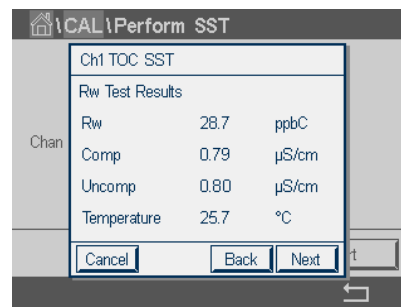
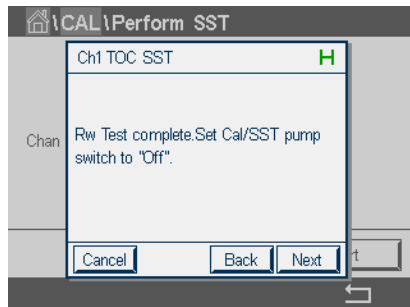

- When instructed, attach the R_S bottle to the Cal/SST module and activate the pump. Press 'Next' when ready to proceed.

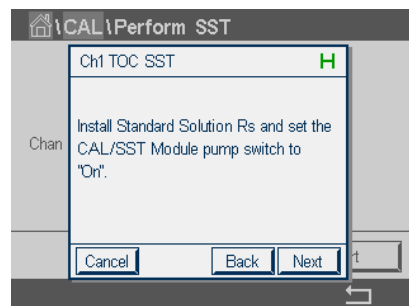

- After completing an automatic purge countdown, the system will monitor the TOC reading to determine stability and then automatically record the readings once stable.

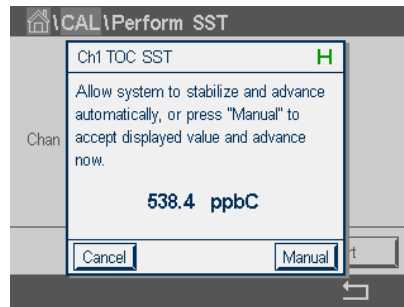

If a system fault prevents the readings from automatically stabilizing, 'Manual' can be pressed to complete the SST process. Using 'Manual' to complete the SST process should be used only for diagnostic purposes, and should not be used for determination of System Suitability.

- When instructed, turn of the Cal/SST module pump and press 'Next' to display the R_s test results. If desired, record the results in Section 3 of the System Suitability Worksheet at the end of this document, or on an equivalent document. Press 'Next' when ready to proceed.

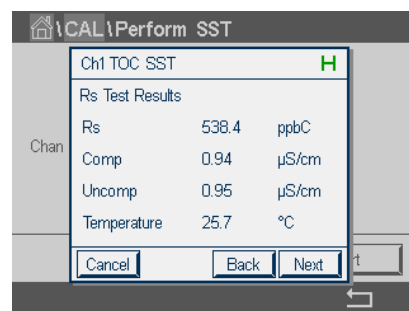
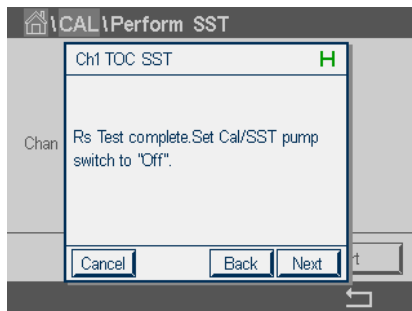

- When instructed, attach the R_{SS} bottle to the Cal/SST module and activate the pump. Press 'Next' when ready to proceed.

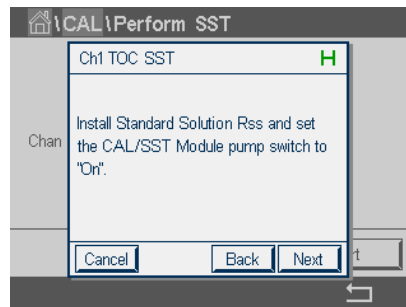

- After completing an automatic purge countdown, the system will monitor the TOC reading to determine stability and then automatically record the readings once stable.

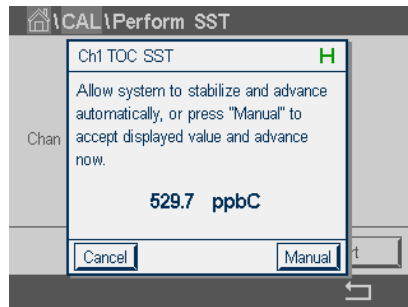

If a system fault prevents the readings from automatically stabilizing, 'Manual' can be pressed to complete the SST process. Using 'Manual' to complete the SST process should be used only for diagnostic purposes, and should not be used for determination of System Suitability.

- When instructed, turn off the Cal/SST module pump and press 'Next' to display the R_{SS} test results. If desired, record the results in Section 3 of the System Suitability Worksheet at the end of this document, or on an equivalent document. Press 'Next' when ready to proceed.

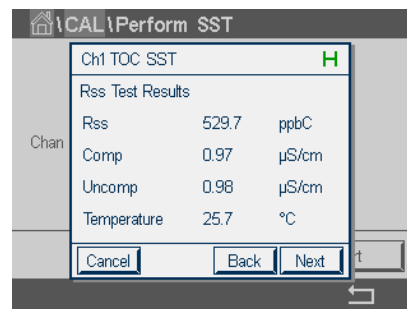
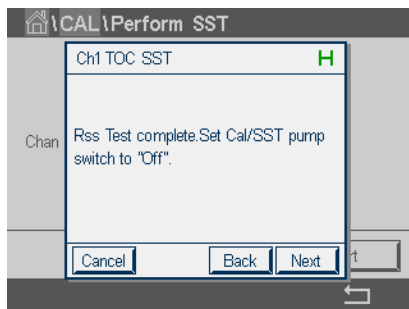

- The M800 will now display a summary of the results of the System Suitability Test. Press 'Next' then 'Report' to view the detailed SST report, or press 'Next' to complete the SST process. The detailed SST report can be viewed at any time by pressing the **ISM** icon from the main M800 screen and selecting SST Info.

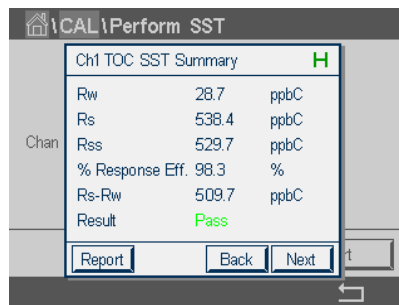

- If desired, record the Response Efficiency and SST Result in section 5 of the System Suitability Test Report, or on an equivalent document.

15. Press 'Save' to save the test results to the 5000TOCi, or press 'Cancel' to abort the SST process and discard the test results and return to the main SST screen.

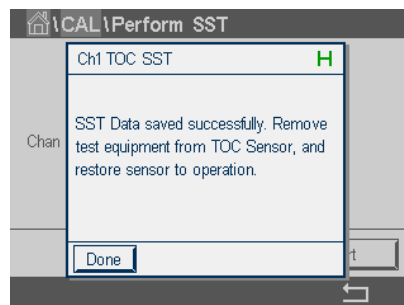
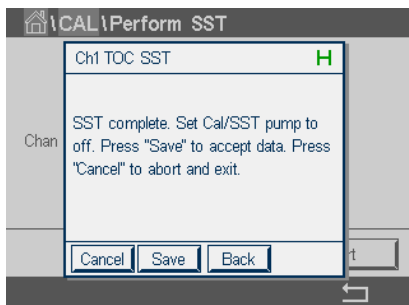

6.5. Rinse Sensor and System Suitability Test Kit

1. Replace the R_{SS} solution bottle with the Reagent Water. If necessary, use the second bottle of Reagent Water or your process water.
2. Turn on the pump
3. Rinse the system for at least 5 minutes to flush the system.
4. Turn off the pump.
5. Disconnect the Sensor tubing from the Sensor. The 5000TOCi Sensor may be returned to operation with the Process Water.
6. Remove the reagent water bottle from the SST test device.
7. Turn on the pump for 10 to 20 seconds to remove residual water.
8. Disconnect all the tubes from the pump.
9. Remove the SST device from the 5000TOCi sensor, and re-pack into carry case.
10. Reconnect the process water line, and open the user installed shut-off valve.
11. Verify there is no leak at the process water line, and verify water dripping at the atmospheric drain.

7. Complete System Suitability Test Report

The M800 Transmitter will automatically calculate the necessary values, determine the Pass/Fail results of the System Suitability Test, and store these values in the 5000TOCi Sensor. However, if manual calculation of the results is desired, follow these steps to complete Section 4 of the System Suitability Test Report.

If manual calculation of Response Efficiency is not necessary, proceed to Section 7.3 System Suitability Test Acceptance.

7.1. Limit Response and System Suitability Response

1. The limit response is the corrected Standard Solution response. Fill in Table 5 of the System Suitability Worksheet.
2. Calculate the limit response by subtracting the Reagent Water TOC response from the response of the Sucrose Standard Solution. This is $R_s - R_w$.
3. Record the value $R_s - R_w$ in Table 5 of the System Suitability Worksheet.
4. Calculate the corrected System Suitability Solution response by subtracting the Reagent Water TOC response from the System Suitability Solution TOC response. This is $R_{ss} - R_w$.
5. Record the value $R_{ss} - R_w$ in Table 5 of the System Suitability Worksheet.

7.2. Response Efficiency

1. Enter the appropriate values from the System Suitability Test Report into Section 4 using the following formula:

$$\text{Response Efficiency (\%)} = 100 \times \left(\frac{R_{ss} - R_w}{R_s - R_w} \right)$$

2. Calculate and record the Response Efficiency in the System Suitability Test Report.

7.3. System Suitability Test Acceptance

1. If completing a written report, transcribe the R_w reading recorded in Section 3 to the appropriate location in Section 5 of the System Suitability Worksheet.
2. Verify that the Reagent Water is <100 ppb.
3. Verify that the Response Efficiency is not less than 85% and not more than 115%*.
4. If the conditions stated in Step 2 and Step 3 are met, then the System Suitability Test indicates that the TOC sensor meets the requirements of USP <643> and EP 2.2.44.

* These values are correct at time of printing. Consult your pharmacopeia for current requirements.

System Suitability Test Report

Section 1. TOC System Information				
Date of test		5000TOCi Sensor ID		
5000TOCi Sensor S/N		M800 Transmitter S/N		
5000TOCi Sensor P/N		M800 Transmitter P/N		
5000TOCi Sensor S/W Version Number		M800 Transmitter S/W Version Number		
5000TOCi Sensor H/W Version Number		M800 Transmitter H/W Version Number		
Comments				
Section 2. System Suitability Test Solution Information				
Material	Use By Date	Lot number	Concentration*	
Reagent Water (R _w)				
Sucrose (R _s)				
1,4-Benzoquinone (R _{ss})				
Comments				
Section 3. TOC Measurements				
Reading	TOC (ppb)	Compensated Conductivity (µS/cm)	Uncompensated Conductivity (µS/cm)	Temperature (°C)
Reagent Water (R _w)				
Sucrose (R _s)				
1,4-Benzoquinone (R _{ss})				
Comments				
Section 4. Response Efficiency Calculation**				
Limit Response (sucrose) = R _s -R _w = _____ (R _S) ppb - (R _W) ppb = ppb				
System Suitability Response (1,4-benzoquinone) = R _{ss} -R _w = _____ (R _{SS}) ppb - (R _W) ppb = ppb				
$\text{Response Efficiency (\%)} = RE = 100 \times \left(\frac{R_{ss} - R_w}{R_s - R_w} \right) = 100 \times \left(\frac{\text{---} - \text{---}}{\text{---} - \text{---}} \right) = \text{---} \%$				
Comments				
Section 5. System Suitability Test Acceptance				
Measurement	Reading	Specification	Result (Pass / Fail)	
R _w (From Section 3)		< 100 ppb		
Response Efficiency		85% < % Response Eff < 115%		
System Suitability Test Result	Response Efficiency and R _w tests above, both indicate 'Pass'			
Performed By:			Date:	
Reviewed By:			Date:	
Comments				

* This is the labeled or prepared concentration. This is not the concentration as measured by the TOC system.

**Optional

Mettler-Toledo Thornton, Inc.

36 Middlesex Turnpike

Bedford, MA 01730

Tel. +1-781-301-8600

Fax +1-781-301-8701

Toll Free +1-800-510-PURE (US and Canada only)

thornton.info@mt.com

www.mt.com/thornton _____

Part 58130258

Rev.A 12/11